

On the Method of Modified Blueweb: A Decentralized Bluetooth Scatternet Formation Algorithm

Chih-Min Yu

*Dept. of Communication Engineering, Chung-Hua University
No. 707, Sec 2, Wufu Rd, Hsinchu, 30012, Taiwan, R.O.C
E-mail:ycm@chu.edu.tw*

Abstract—In the paper, a decentralized scatternet formation algorithm called Modified Blueweb is proposed. Modified Blueweb is a tier-based method to determine new roots and each new root spontaneously generates their individual web-shaped subnets. First, Modified Blueweb uses a designated root to construct a tree-shaped subnet and propagates a counter limit kl as well as a constant k in its downstream direction to determine new roots. Then each new root asks its upstream master to start a return connection procedure to convert the tree-shaped subnet into a web-shaped subnet for its immediate upstream root. At the same time, each new root repeats the same procedure as the designated root to build its own subnet until the whole scatternet is formed. Simulation results show that the subnet size can be controlled by appropriated selecting the k parameter and each root manages its subnet decentralized. Therefore, Modified Blueweb achieves good network scalability and generates an efficient scatternet configuration for various sizes of Bluetooth scatternet.

Keywords—Bluetooth, ad hoc network, scatternet formation, network scalability

1. INTRODUCTION

Bluetooth is emerging as a potential technology for short-range wireless ad hoc network. This technology enables the design of low power, low cost, and short-range radio which is embedded in existing portable devices. Initially, Bluetooth technology is designed as a cable replacement solution among portable and fixed electronic devices. Today, people tend to use a number of mobile devices such as cellular phones, PDA's, digital cameras, laptop computers, and so on. Consequently, there exists a strong demand

for connecting these devices into networks. As a result, Bluetooth becomes an ideal candidate for the construction of ad hoc personal area networks.

Until now, many scatternet formation algorithms for constructing a Bluetooth ad hoc network have been proposed. In general, these algorithms can be divided into two categories: the coordinated methods and the distributed methods [1]. The coordinated methods [2]-[4] commonly use a coordinator node to construct the whole scatternet. On the other hand, the distributed methods [5]-[7] usually select a leader to form the piconet locally and merge piconets to build up the whole scatternet.

In [2], two scatternet formation algorithms are proposed. One is Bluetree and the other one is Distributed Bluetree. Bluetree uses a root node to start the scatternet formation process and then constructs the whole scatternet. This algorithm can be implemented easily but the root node is likely to become the bottleneck. The Distributed Bluetree operates in two phases. In the first phase, root nodes are elected and local subnets are formed. In the second phase, the subnets are merged through their leaf nodes until the whole scatternet is built. Finally, each root node manages its own tree-shape subnet.

In order to avoid the root node bottleneck problem and decentralized to manage the scatternet, a tier-based scatternet formation method called Modified Blueweb is proposed. This method uses a designated root to construct its own subnet and simultaneously propagates a counter limit kl as well as a constant k in its downstream direction to determine new roots. Afterwards, each new root repeats the same procedure to build its own subnet until the whole scatternet is formed. With the method, we can control and achieve good network scalability for various sizes of Bluetooth scatternet.

The paper is organized as follows: In Section 2, we review the Blueweb scatternet formation

process. In Section 3, we describe the scatternet formation algorithm of the Modified Blueweb. In Section 4, we use computer simulations to verify the system performance of Modified Blueweb. Finally, a conclusion is drawn in Section 5.

2. BLUEWEB REVIEW

2.1. Scatternet Formation Process

In Blueweb, the scatternet formation process includes two phases. In the first phase, a designated root starts to create a tree-shaped topology and in the second phase the tree-shaped topology is converted into a web-shaped topology. A role exchange mechanism is used in the first phase to make slaves function as relays. In the second phase, a return connection mechanism is used to generate more connection paths among nodes.

Fig. 1 is an example to review the Blueweb scatternet formation process [4]. In the beginning of the first phase, the designated root initiates the scatternet formation procedure by paging up to 7 neighboring slaves, and forms the first piconet, as shown in Fig. 1(a). The slaves then switch their roles to masters (called S/M nodes). Each S/M node pages only one additional neighboring slave, as shown in Fig. 1(b). After these S/M nodes connect to their slaves, a role exchange mechanism is executed such that the S/M nodes switch their roles to relays (called S/S nodes) and their slaves switch their roles to masters, then the new masters begin to page up to 7 neighboring slaves, as shown in Fig. 1(c). This procedure is operated iteratively until the leaf nodes of the tree are reached.

In the second phase, each leaf node will request either itself (if it is a master) or its immediate upstream master to function as a returning master and start a return connection procedure. A returning master will page any available neighboring slave and connect with it. If this new link is established, the slave switches its role to a relay (S/S node), as shown in Fig. 1(d). Then the returning master will ask its immediate upstream master to function as the next returning master. This return connection procedure is operated iteratively in the upstream direction until the designated root is reached. As a result, the designated root can manage the whole scatternet with global topology information.

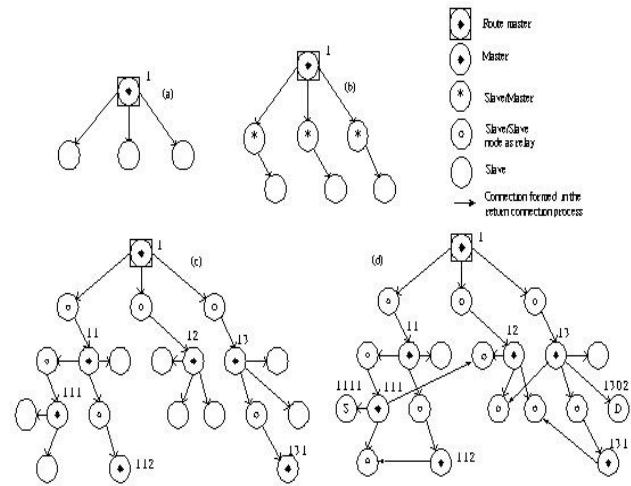

Fig. 1 Blueweb scatternet formation process

2.2. Routing Protocol

In the Blueweb scatternet formation period, some routing information can be exchanged among masters. In the first phase of scatternet formation, each master keeps a record of its directly connected upstream master. As a result, a query path can be easily formed by connecting all the masters in the upstream direction to the route master.

In the second phase of scatternet formation, each returning master will pass its own piconet information together with a list of its directly connected masters to the route master via its upstream masters. At the same time, each returning master including the route master will pass its own piconet information to its directly connected masters. Here, we define the directly connected neighboring piconets within its neighboring N tiers of a master as the N -tier piconets of the master. The associated N -tier piconet information will be stored in the master's N -tier piconet table. In addition, those masters affected by the return connection mechanism will update their N -tier piconet table via relays. As a result, each master will keep its own piconet information and its N -tier piconet information. This information is used locally when a node inquires the master for a path to deliver packets.

After finishing the second phase of scatternet formation, the route master will have the routing information of all nodes and store it in a piconet list table. This table contains a list of all the masters and their associated slaves. Meanwhile, the route master will compute the shortest path for any two-piconet pair using the all-pairs shortest path algorithm. This shortest path information is stored in a scatternet routing

table and is used when any node inquires the route master for routing information to deliver packets.

In order to implement this routing protocol, a piconet-layer addressing scheme can be used. This scheme combines the Bluetooth active member address (AM_ADDR) with piconet identification (PID) to address each Bluetooth device throughout the whole scatternet. In a piconet, each slave is assigned a 3-bit AM_ADDR by its master. In addition, the PID is used to distinguish different piconets in the scatternet.

The PID's are assigned on a layer-by-layer basis in the downstream direction during the first phase of scatternet formation. For example, the route master is the only layer 1 node and uses 1 as its PID. Its first attached master is assigned 1.1 as its PID, the second attached master is assigned 1.2 as its PID, and so on. In this way, a layer 3 master will be assigned a PID of 1.a2.a3. We refer this addressing method as a piconet-layer addressing scheme. This addressing scheme can be applied to Blueweb architecture directly. An example of this scatternet addressing scheme for Blueweb is shown in Fig. 1.

Based on the routing information collected by all the masters including the route master, a modified source routing protocol is developed. This is a hybrid routing protocol and operates in two phases. In the first phase, an optimal path from source to destination is searched. In the second phase, the optimal path is used to transmit the packets. Overall, the detailed Blueweb routing algorithm is described by the pseudo code listed in Fig. 2.

```

Routing algorithm Q {
  If the source node is a master
    It checks whether it has its destination's routing information
    If this master has destination's routing information
      The source node transmits its packets directly
    Else it forwards the query message to the route master
      The route master replies the routing path to the source node
      The source node transmits its packets by source routing
    End
  Elseif this node is a relay or slave
    The source node queries its immediate upstream master
    If this master has its destination's routing information
      It replies the routing path to the source node
      The source node transmits its packets using the routing path
    Else it forwards the query message to the route master and
      The route master replies the routing path to the source node
      The source node transmits its packets using the routing path
    End
  End
}

```

Fig. 2 Blueweb routing algorithm

3. MODIFIED BLUEWEB SCATTERNET FORMATION ALGORITHM

Based on the original design of Blueweb, Modified Blueweb adds a new root selection process to determine new roots on a tier-by-tier basis in the downstream direction (out from the designated root) during scatternet formation. Each new root constructs and coordinates its own local web-shaped subnet.

At the beginning, the designated root sets a counter limit $kI=k$ where k is the constant. With these two parameters, the first root pages up to 7 neighboring slaves, and forms its own piconet. Each slave then switches its role to master (called S/M node) and pages one additional slave. After each S/M node connects to its slave, a role exchange mechanism as Blueweb is executed to make the S/M node function as a relay and make the slave function as a master. Then, these new masters decrease kI by 1 and continue to propagate the two parameters in the downstream direction.

In this way, when the $(kI)th$ master is reached, $kI=0$ and the master becomes a new root and the counter limit kI is reset to k . The tree-shaped subnet of the designated root is created. Then this new root asks its upstream masters to start the return connection procedure and tries to connect with one additional piconet until its immediate upstream root is reached. As a result, the tree-shaped subnet of the designated root is converted into the web-shaped subnet.

At the same time, the new root repeats the same procedure as the designated root to build its own subnet and propagates the two parameters to determine new roots. This procedure is continued until the leaf nodes are reached. All the leaf nodes will request their immediate upstream masters to conduct the return connection procedure until its immediate upstream root is reached, and the whole scatternet is formed. Finally, each root manages its own web-shaped subnet.

Here, we use $k=2$ in Fig. 3 as an example to describe the Modified Blueweb scatternet formation process. At the beginning, the designated root R1 connects with the first tier masters, as shown in Fig. 3(a). Then the first tier masters decrease kI by 1 and continue to connect with their downstream masters. When the second tier masters are reached and the counter limit $kI=0$. Then these masters become new roots and reset kI to k , as shown in Fig. 3(b). The tree-shaped subnet of the designated root is created.

Then these new roots ask their upstream masters to start the return connection procedure until R1 is reached. The topology of the designated root is finished and it generates a web-shaped subnet. At the same time, these new roots start to page new slaves and connect with their immediate downstream masters (leaves in this example), as shown in Fig. 3(c) to build their own tree-shaped subnets.

When the leaf masters are reached, these masters start the return connection procedure until their immediate upstream roots R2's are reached, and the scatternet formation process is terminated. Finally, all roots have their corresponding web-shaped subnet, as shown in Fig. 3(d). In order to simplify the illustration, relays (S/S node, used to interconnect masters among piconets) are not shown in Fig. 3.

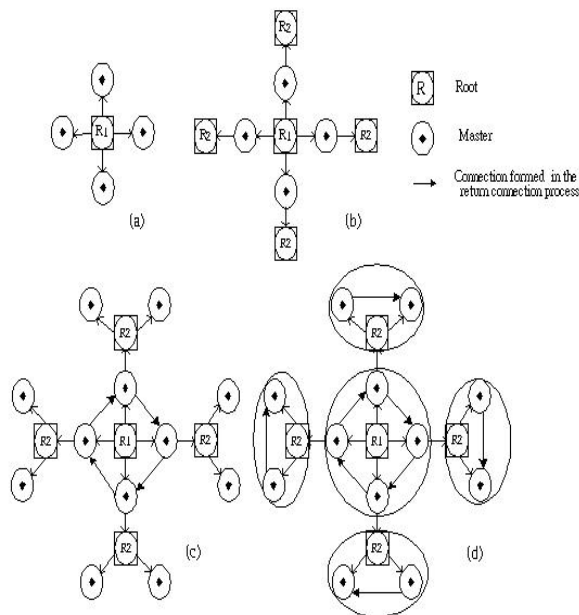

Fig. 3 The modified Blueweb scatternet formation process

The Modified Blueweb architecture has the following features. First, the new root selection process is more efficient than Distributed methods since it introduces much less communication overheads in electing new roots. Second, each new root only constructs and maintains its own local subnet and it generates relatively low operation cost. Third, using both k and $k1$ parameters, the subnet size is controllable. As a result, Modified Blueweb achieves good network scalability for various sizes of Bluetooth scatternet.

4. MODIFIED BLUEWEB SYSTEM PERFORMANCE SIMULATION

4.1. Simulation Model and System Parameters

A simulation program based on Matlab is written to evaluate the system performance. First, we assume that the Bluetooth nodes are uniformly located on a rectangular lattice and the number of neighboring nodes which can be reached by each node is between 2 and 4. The simulated node number ranges from 60, 70, 80,..., to 150. The page time is set to 1.28 second and the page scan time is set to 0.64 second. A set of performance metrics is calculated by averaging over 100 randomly generated topologies for each simulated node number. The constant k is varied from 1, 2, 3, to 4 and the simulation results of Modified Blueweb are shown as follows.

4.2. Performance Results

Fig. 4 shows the performance on average number of roots for both Modified Blueweb and Distributed Bluetree. The average number of roots increases as the number of nodes increases. In Modified Blueweb, we observe that the number of roots decreases as k increases and the $k=4$ case produces the smallest number of roots than all the other cases. In addition, the $k=2$ case produces almost the same performance as the Distributed Bluetree. As a result, the number of roots can be easily controlled for various sizes of Bluetooth scatternet by selecting an appropriate k value in the Modified Blueweb.

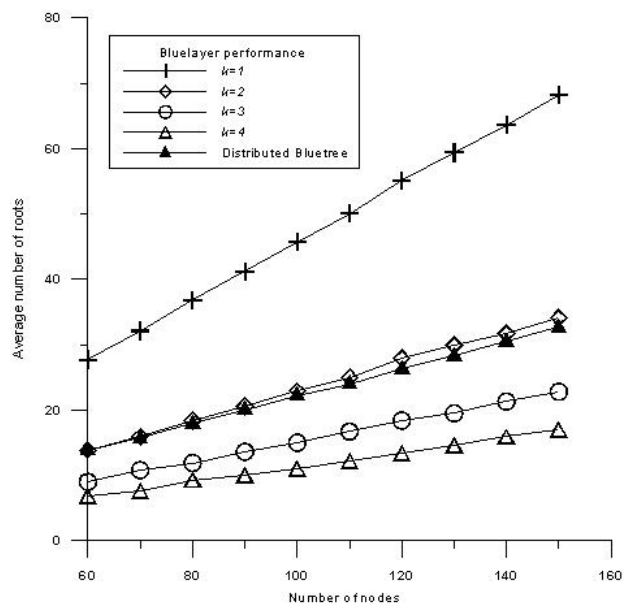

Fig. 4 Average number of roots in a scatternet

Fig. 5 shows the performance on average subnet size for both Modified Blueweb and Distributed Bluetree. The $k=4$ case produces the largest average subnet size since it generates the least number of roots than all the other cases. In addition, the subnet size can also be controlled by appropriately selecting the k parameter. Moreover, each new root in Modified Blueweb only manages its own subnet and this strategy introduces much less operation cost.

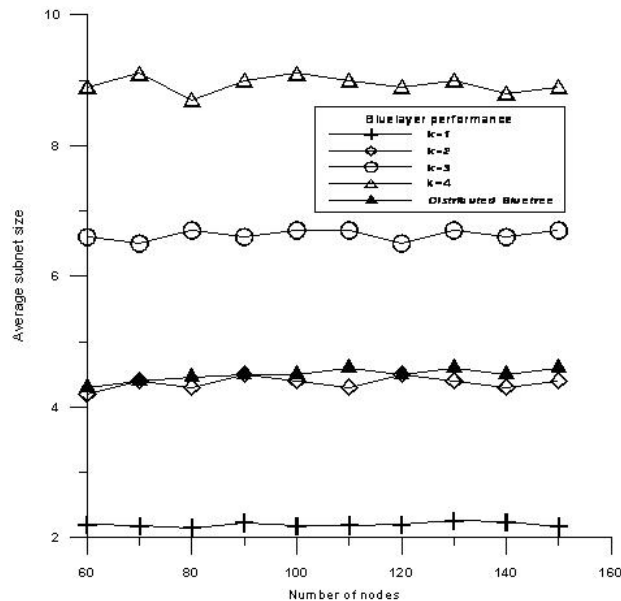

Fig. 5 Average subnet size in a scatternet

5. CONCLUSIONS

Our Modified Blueweb is a tier-based method to generate new roots and spontaneously construct their own subnets locally until the whole scatternet is formed. This method uses a counter limit $k1$ and a constant k as parameters to generate new roots. Finally, each root decentralized maintains its own web-shape subnet. By selecting appropriate k value, we can achieve good network scalability for various size of Bluetooth scatternet. In addition, the proposed new root selection process is more efficient than the Distributed Bluetree because it generates much less communication overheads in electing new roots. Simulation results show that Modified Blueweb achieves better network scalability by selecting k value appropriately. As a result, Modified Blueweb generates an efficient scatternet configuration for various sizes of Bluetooth scatternet.

REFERENCES

- [1] K. Persson, D. Manivannan, and M. Singhal, "Bluetooth Scatternet Formation: Criteria, Models and Classification," *First IEEE Consumer Communication and Networking Conference*, 2004.
- [2] Zaruba, G.V., Basagni, S. and Chlamtac, I. "Bluetrees-scatternet formation to enable Bluetooth-based ad hoc networks," *IEEE International Conference on Communications*, vol.1, pp. 273 -277, June 2001.
- [3] Salonidis, T., Bhagwat, P., Tassiulas, L. and LaMaire, R. "Distributed topology construction of Bluetooth personal area networks," *IEEE Journal on Selected Area in Comm.*, vol. 23, pp. 633-643, March 2005.
- [4] Chih-Min Yu, Shiang-Jiun Lin, and Chia-Chi Huang, "On the Architecture and Performance of Blueweb: A Bluetooth-based Multihop Ad Hoc Network", *IEICE Transaction on Communication*, vol. E89-B, No. 2, pp.482-489, Feb. 2006.
- [5] Zhifang Wang, Thomas, R.J., and Haas, Z., "Bluenet - A new scatternet formation scheme," *Proceedings of the 35th Annual Hawaii International Conference on System Sciences*, pp. 779-787, 2001.
- [6] Stefano Basagni and Chiara Petrioli, "Multihop scatternet formation for Bluetooth networks," *Vehicular Technology Conference*, pp.424-428, May 2002.
- [7] Chiara Petrioli, Stefano Basagni, and Imrich Chlamtac, "ConFig.uring BlueStars: Multihop scatternet formation for Bluetooth networks," *IEEE Transaction on Computers*, vol. 52, no.6, pp.779-790, June 2003.