

# Application of Cloud Temperature Sensor on Robotic Arm's Temperature Measurement

Chin-Yu Hsu, Lien-Cheng Chen

#\* Dept. Of Information and Communication Engineering, Chaoyang University of Technology  
168, Jifeng East Road, Wufeng Dist, Taichung City 41349, Taiwan, R.O.C.

tccnhsu@gmail.com

s10230616@gm.cyut.edu.tw

**Abstract**—With the arrival of Industry 4.0 [1] and Internet of Things (IoT) [2] era, machines have gradually replaced human. However, after working for long hours human will feel tired and take a rest. On the contrary, machines are different from human in that it will not take the initiative to make an adjustment, but usually will not stop working until they are damaged or overloaded. This paper focuses on the temperature change in an robotic arm, and aims to detect the temperature warning in the robotic arm's motor before it is overheated and shut down, and then aims to stop the robotic arm's action until it cools down in order to effectively prolong the machine life. A self-made SCARA (selective compliance assembly robot arm) [3] is combined with an Arduino Yún (cloud) development board and a LM35 temperature sensor for data collection, and then the data is transmitted to the cloud to form a cloud temperature sensor. Therefore the temperature in the robotic arm can be remotely monitored anytime.

**Keywords**—industrial automation, Arduino Yún, temperature sensing, the use of cloud

## 1. Introduction and design

The self-made SCARA robot arm is the subject for the experiment in this paper. The reason for selecting this type of machine arm is because of the rotating characteristics of its first, second and fourth axis, and the linear movement characteristics of its third axis. This type of robotic arms therefore have high adaptability and are mainly used for handling and assembly work, and widely used in automobile, electronic, plastic, medicine, food and other industries. In addition, Arduino micro control board also evolved from the original Arduino Uno to Arduino Yún with a built-in cloud function, which can more easily transmit data to the cloud.

In this paper the system architecture is divided into two parts as follows:

### A) Assembly of the experimental robot

The experiment is based on the requirements of the domestically-made industrial robotic arm SCARA to find relevant sample data or assembly drawing. SolidWorks is used to establish the basic architecture, which is modified with the experimental needs. The mechanical design is shown in Figure.1, which the processing and assembling are based on. On the motor and the controller, currently Hiwin and Delta Electronics dominate the industrial robot production and R&D in Taiwan, and Delta Electronics' equipment is selected as the control unit in this experiment with instructions issued from a personal computer. In addition, a temperature sensor is fitted in the servomotor to transmit the data collected to Google Cloud and achieve remote monitoring and extend the life of the robotic arm.

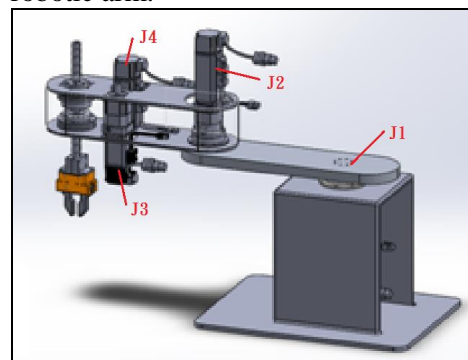

Figure.1 Mechanical design

### B) Cloud temperature sensor

In this paper Arduino Yún [4] micro control board is used as the development focus, coupled with LM35 temperature sensor to collect temperature data. The following is a basic introduction to Arduino Yún. This board has a micro control block ATmega32u4 which is combined with AR9331 of Atheros. The Atheros processor is based on a cloud named OpenWrt

for the Linux version. The board also has built-in Ethernet and wireless network support, a USB interface and a micro-SD card slot, as well as 20-digit input/output pins (7 of which can be used for PWM output and 12 for analog input), a 16 MHz crystal oscillator, an ICSP plug and a reset button as shown in Figure.2.

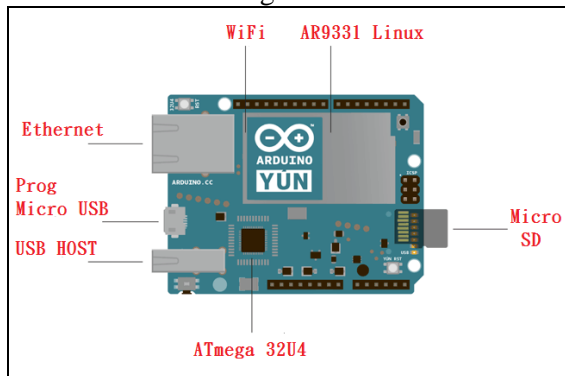

Figure.2 Arduino Yún (cloud) micro control board

From the network transmission chart in Figure.3 we can see that the left half is the original Arduino Leonardo design, and the right half is the AR9331 module, officially called the Linino (containing a Linux) system. These two halves communicate with each other through UART, which can be thought of as a combination of Arduino and a XBEE ZigBee module. Arduino relies on the UART protocol to transmit data to the network through Linino.

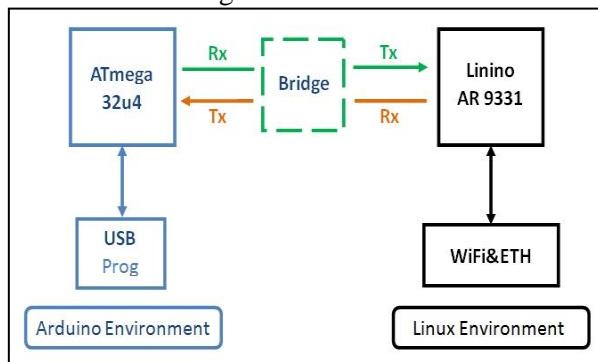

Figure.3 Network transmission chart

### C) LM35 temperature sensor [5]

Because the integrated application of automatic control and electromechanical components is becoming more and more popular, temperature measurement becomes more important. There are many types of temperature sensing products, which according to their characteristics can be divided into the expansion type, the color change type, the resistance change type, the electric current change type, the voltage change type and the frequency change type. Here

a common voltage change type LM35 is illustrated as follows. Figure.4 shows the LM35 foot bitmap. There is a linear relationship between the LM35 output voltage and the Celsius temperature. This paper uses the Celsius temperature as it is more widely used. The conversion formula is shown in Formula.1: at 0 °C the output is 0V, and the output voltage increases by 10mV for every 1 °C increase. At room temperature LM35 does not require an additional calibration process to achieve the  $\pm \frac{1}{4}^{\circ}\text{C}$  accuracy rate.

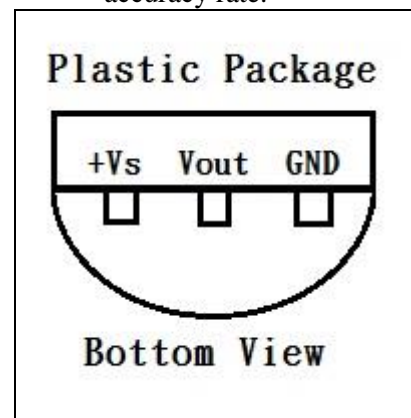

Figure.4 LM35 foot bitmap

$$\text{Formula.1 } V_{\text{out\_LM35}}(T) = 10\text{mv}/^{\circ}\text{C} \times T^{\circ}\text{C}$$

## 2.System operation process

The system operation process is shown in the system operation flowchart in Figure.5. In the robotic arm's continuous operation the cloud temperature sensor collects the numerical value once every five seconds, and then transmits the collected data to Google Cloud to display the record in a curve graph. The threshold value will be used as the judgment criteria. If the threshold value is more than 70 degrees and exceeds the operating temperature range, the system will issue a warning in a window. The central remote monitoring staff of automatic control will then check the temperature status and decide whether it is necessary to temporarily stop the operation and then restart after troubleshooting. Otherwise, the robotic arm will continue to operate if the threshold is not exceeded.

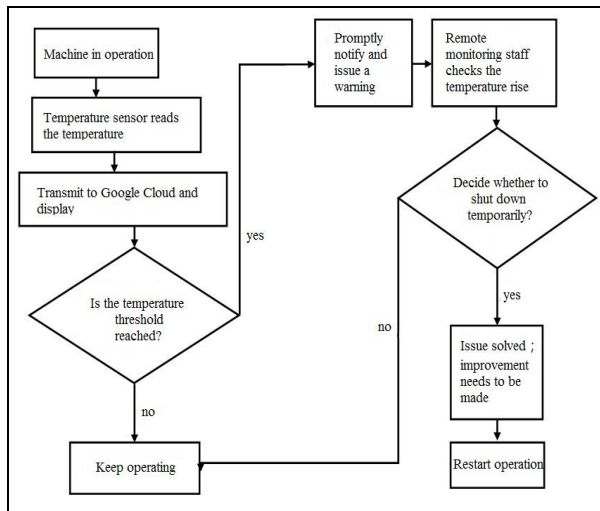

Figure.5 System operation flowchart

### 3.Experimental results

In the self-made four-axis SCARA robotic arm of this paper a motor made by Delta Electronics is selected for the operation, and a teaching device which matches the motor is used for its operation. Moreover, a temperature sensor is set in each motor axis to collect temperature data. The temperature value collected is transmitted to Google Cloud through Arduino Yún and displayed in a curve graph, which enables the central monitoring staff to ensure that the four-axis motor operates within a temperature range at any time.

#### a) System planning

The matching driver software DRAS [6] is used for writing a script to send instructions in order to achieve the following functions:

1. Coordinate measurement
2. Robotic arm position control for grabbing
3. Accuracy of positioning
4. Accuracy of repetition

The driver-compatible control software (DRAS) is connected to the controller with a software jog interface as in Figure.6-1 and the rotation degree of each motor axis as in Figure.6-2 through RS232 on a personal computer. A cloud temperature sensor is installed on the motor as shown in Figure.7. The cloud application used is the space provided by Google Cloud, and the program is written in C# to allow the transmission of Arduino Yún data to Google Cloud and the display in a curve graph. A warning mechanism is added, and a warning is sent to notify the central monitoring staff through

a window if the temperature exceeds a certain range.



Figure.6-1 Software jog interface



Figure.6-2 Rotation degree of each motor axis

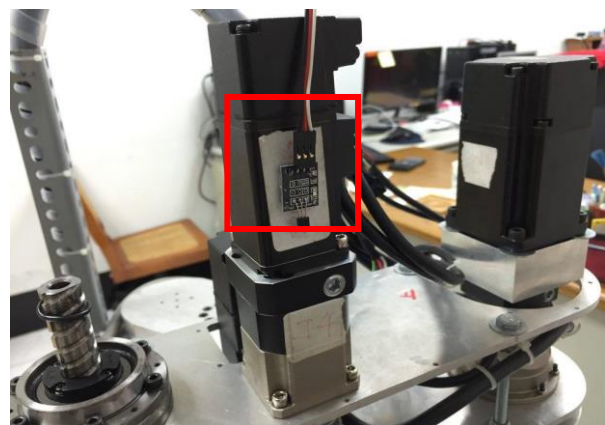

Figure.7 Location of temperature sensor in the motor

In this paper a one-minute temperature curve is presented, and the temperature is updated every 5 seconds, as shown in the four-axis temperature graph of Figure.8. In the graph J1 to J4 are the codes for the first axis to the fourth axis. As the robotic arm operates within the positioning accuracy, in J1 and J2 the load is larger and the temperature rises faster. The temperature threshold is set at 70 degrees. A warning window will appear, as shown in Figure.9, to notify the user if the temperature threshold is exceeded.

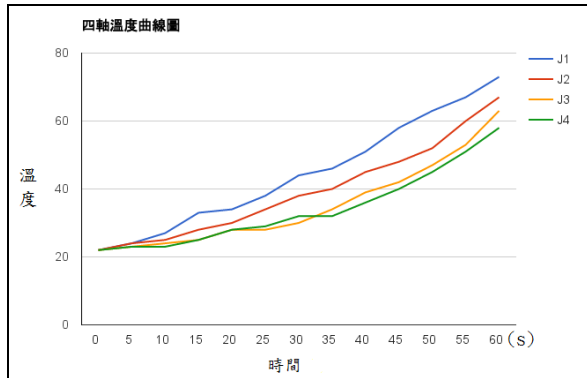

Figure.8 Four-axis temperature curve graph

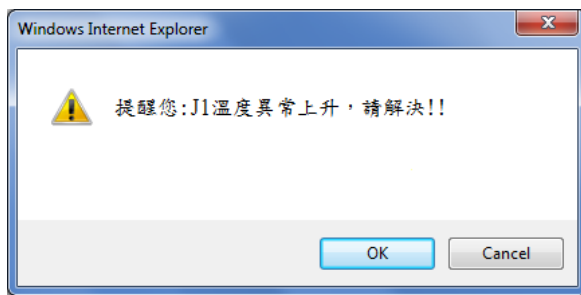

Figure.9 Warning window

#### 4. Conclusions and future goals

In this study the combination of a self-made robotic arm and the cloud temperature sensing system proved to be successful in the monitoring of temperature change. Abnormal temperature rise from motor idling will result in the burning of the robotic arm, but after the installation of the cloud temperature sensing system the situation can indeed be detected in advance and solved.

Automation is the trend in all industries, and robotic arms will ultimately replace human. The government is actively promoting Industry 4.0, which will be gradually realized and applied in industrial robots, but is currently exploring a specific direction. At this stage the manufacturing cost of a robotic arm is still quite expensive, and it is not easy to maintain its life. Solving the

abnormal temperature rise issue is essential in allowing a robotic arm to work in a stable condition. It is our hope that the cloud temperature sensing system can be used to extend a machine's life. As mobile phone functions become more diverse, in the future there is an opportunity to use APP software to achieve more rapid and efficient monitoring.

#### REFERENCES

- [1] Sabine Spinnarke "Industrie 4.0-Smartere Produkte und Fabriken revolutionieren die Industrie" am 10.Mai 2012.
- [2] ITU-released "ITU Internet Report 2005 : Internet of Things, IoT"
- [3] Wen-Yun Wang "Control Design and Novel Applications for the SCARA Robot" 2015.
- [4] Ming-Chun Chen "A Smart-Phone Controlled Vehicle Based on WiFi with Real-Time Video Transmission"2014.
- [5] Datasheet DS005516, National Semiconductor Corporation. "LM35 Precision Centigrade Temperature Sensors" 2000.
- [6] DELTA Operating Manual